

**Features:**

□ **27-780**

- Low Consumption 1.0 gpf (3.8 Lpf)
- Commercial Size
- Integral Flush Spreader
- Extended Shields
- Dual Hangers
- For Exposed Flushometer (top spud) 1" x 3/4" Inlet
- 2" S.P.S. Female Outlet Connection Supplied
- Strainer not included



27-780 Urinal  
Shown

**Technical Information:**

Configuration	Wall Mount
Water per flush	1.0 gpf (3.8 lpf)
Outlet	2"
S/B Inlet Spud	3/4"
Height	26 15/16" (685mm)
Width	19 1/8" (485mm)
Depth	12 3/16" (310mm)
Product Weight	52 lbs

**Accessories:**

- None

**Available Colors:**

- White only

**Warranty:**

- 10 year warranty

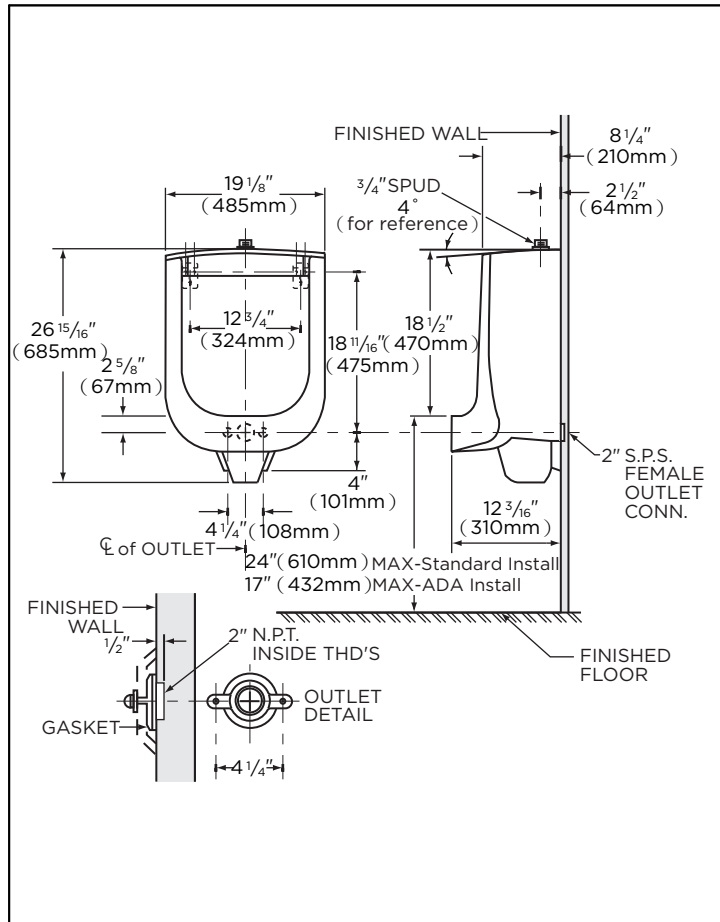

**NOTES:** All dimensions are in inches and millimeters. Use flush valve MFR'S recommended rough-in.  
 Recommended static water pressure for plumbing fixtures is 20-80 psi static per ANSI standards A112.19.2 Appendix B.  
 Illustrations may not be drawn to scale.

**IMPORTANT:**  
 Dimensions of fixtures are nominal and may vary within the range of tolerances established by ASME Standard A 112.19.2.  
 THIS FIXTURE QUALIFIES ACCORDING TO ASME TEST PROCEDURES AS A LOW CONSUMPTION URINAL WITH AN  
 AVERAGE CONSUMPTION OF 1.0 gpf (3.8 Lpf) OR LESS.

**PLUMBERS NOTE:** Provide suitable reinforcement for all wall supports.