

Commercial Lockwing

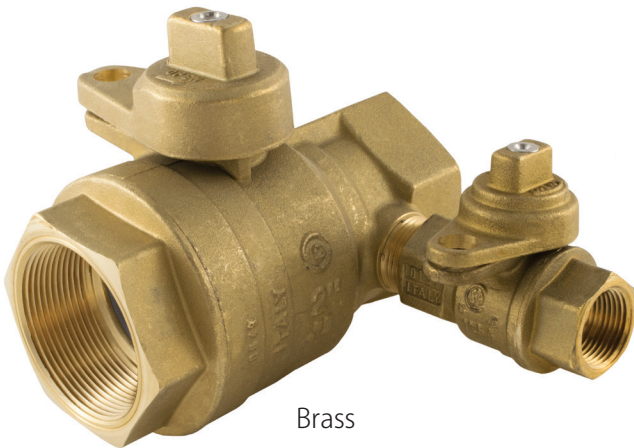

Utility Gas Ball Valve • Full Port • Service Bypass • 175 PSIG



Brass

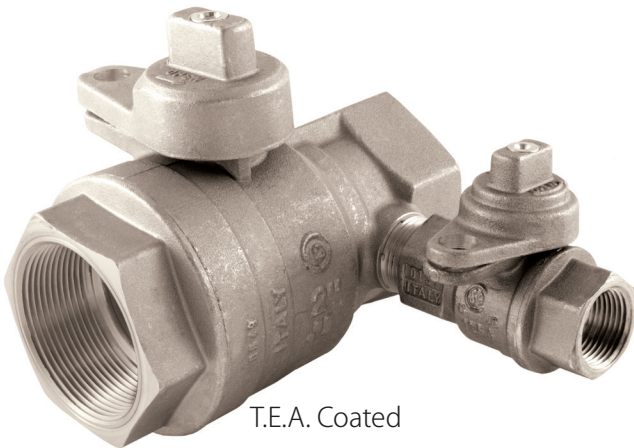

T.E.A. Coated

175-LWBP Commercial

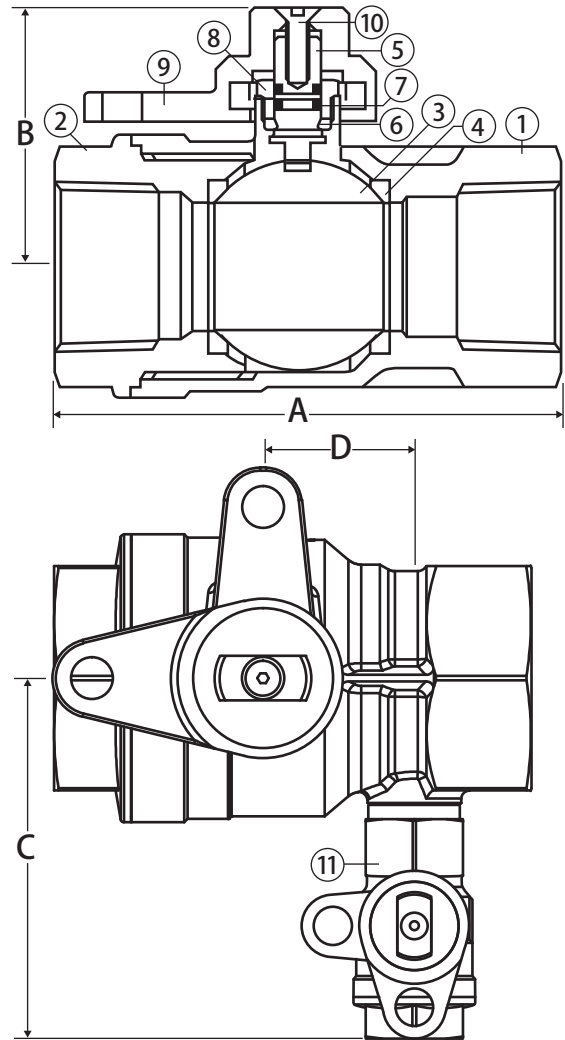

Features

- Tamper resistant lockwing cap
- 2 Viton® o-rings
- Full port design to accommodate industry leading stop changers
- Lockwing accommodates standard barrel locks
- Maintenance free design
- 100% leak tested
- 100% Made in Italy
- Leakproof stem - Lifetime Warranty
- 3/4" bypass valve

Approvals

- Meets or exceeds applicable part of DOT 192 and ANSI B16.33
- MSS SP-110

Pressure Rating

- 175 PSIG
- Temp range: -40°F to 300°F



WARNING: This product can expose you to chemicals including lead, which is known to the State of California to cause cancer, and lead, which is known to the State of California to cause birth defects or other reproductive harm. For more information go to www.P65Warnings.ca.gov.

Material Specifications

No.	Part	Materials
1	Body*	Brass - CW617N
2	End Connection*	Brass - CW617N
3	Ball	Chrome Plated Brass - CW617N
4	Seat (2)	Hostafion® TFM 1600
5	Stem	Brass - CW614N
6	Packing	Buna-N
7	Stem O-ring (2)	Viton®
8	Packing Gland	Brass - CW614N
9	Lockwing Cap*	Brass - CW617N
10	Screw	304 Stainless Steel
11	Bypass Valve*	(See 175-LWN Spec Sheet)

*Components may be TEA coated depending on selection

Dimensions

Part No.	Size	A	B	C	D
244-006B	1-1/4"	4.54	2.47	4.15	1.38
244-007B	1-1/2"	4.84	3.11	4.37	1.52
244-008_	2"	5.73	3.32	4.51	1.81

_ = Specify coating: D = Brass, T = T.E.A. Coated