

Lockwing



Utility Gas Ball Valve • Full Port • Service Bypass • 175 PSIG • with Insulated Tail Piece



175-LWIBP

Features

- Tamper resistant lockwing cap
- 2 Viton® o-rings
- Full port design to accommodate industry leading stop changers
- Lockwing accommodates standard barrel locks
- Maintenance free design
- 100% leak tested
- 100% Made in Italy
- Leakproof stem - Lifetime Warranty
- Patented security shutter and lockwing tab
 - US Patent no. 6,648,009

Approvals

- CSA Certified
 - ANSI B16.33 (125G)
- Meets or exceeds applicable part of DOT 192
- MSS SP-110

Pressure Rating

- 175 PSIG
- Temp range: -40°F to 300°F

 **WARNING:** This product can expose you to chemicals including lead, which is known to the State of California to cause cancer, and lead, which is known to the State of California to cause birth defects or other reproductive harm. For more information go to www.P65Warnings.ca.gov.

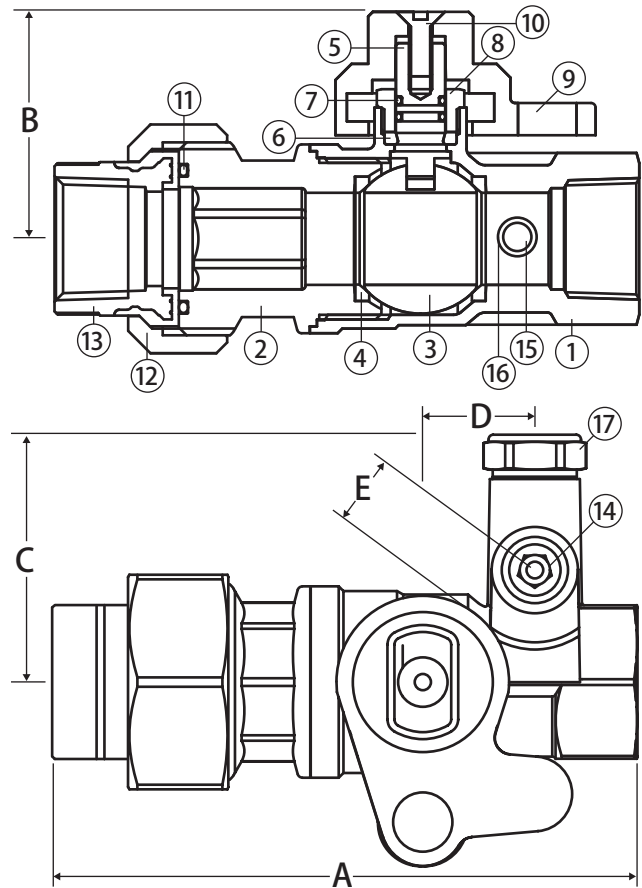

Material Specifications

No.	Part	Materials
1	Body	Brass - CW617N
2	End Connection	Brass - CW617N
3	Ball	Chrome Plated Brass - CW617N
4	Seat (2)	Hostaflon® TFM 1600
5	Stem	Brass - CW614N
6	Packing	Buna-N
7	Stem O-ring (2)	Viton®
8	Packing Gland	Brass - CW614N
9	Lockwing Cap	Brass - CW617N
10	Screw	304 Stainless Steel
11	Union O-ring	Viton®
12	Union Nut	Brass - CW617N
13	Insulated Tail Piece	Zytel® / Brass - CW614N
14	Bypass Plug	Brass - CW614N
15	Bypass Set Screw	Brass - CW614N
16	Bypass O-ring	Viton®
17	Bypass Cap	Brass - CW614N

Dimensions

Part No.	Size	A	B	C	D	E
243-004D	3/4"	4.71	2.06	2.09	0.95	0.59