

**SPECIFICATION:**

JOSAM 30200-AD SERIES CAST IRON FLOOR DRAIN WITH DOUBLE DRAINAGE FLANGE, WEEPHOLES, BOTTOM OUTLET, NIKALOY ADJUSTABLE ROUND STRAINER IN AN ADDJUSTABLE NIKALOY CLAMPING COLLAR WHICH SECURES FLASHING OR WATER PROOFING AT FINISH FLOOR.

**FLOOR DRAIN  
ADJUSTABLE FLOOR DRAIN**

**SERIES**

**30200-AD**

● GASKET ON -Y CONNECTION  
CONFORMS WITH ASTM-C564

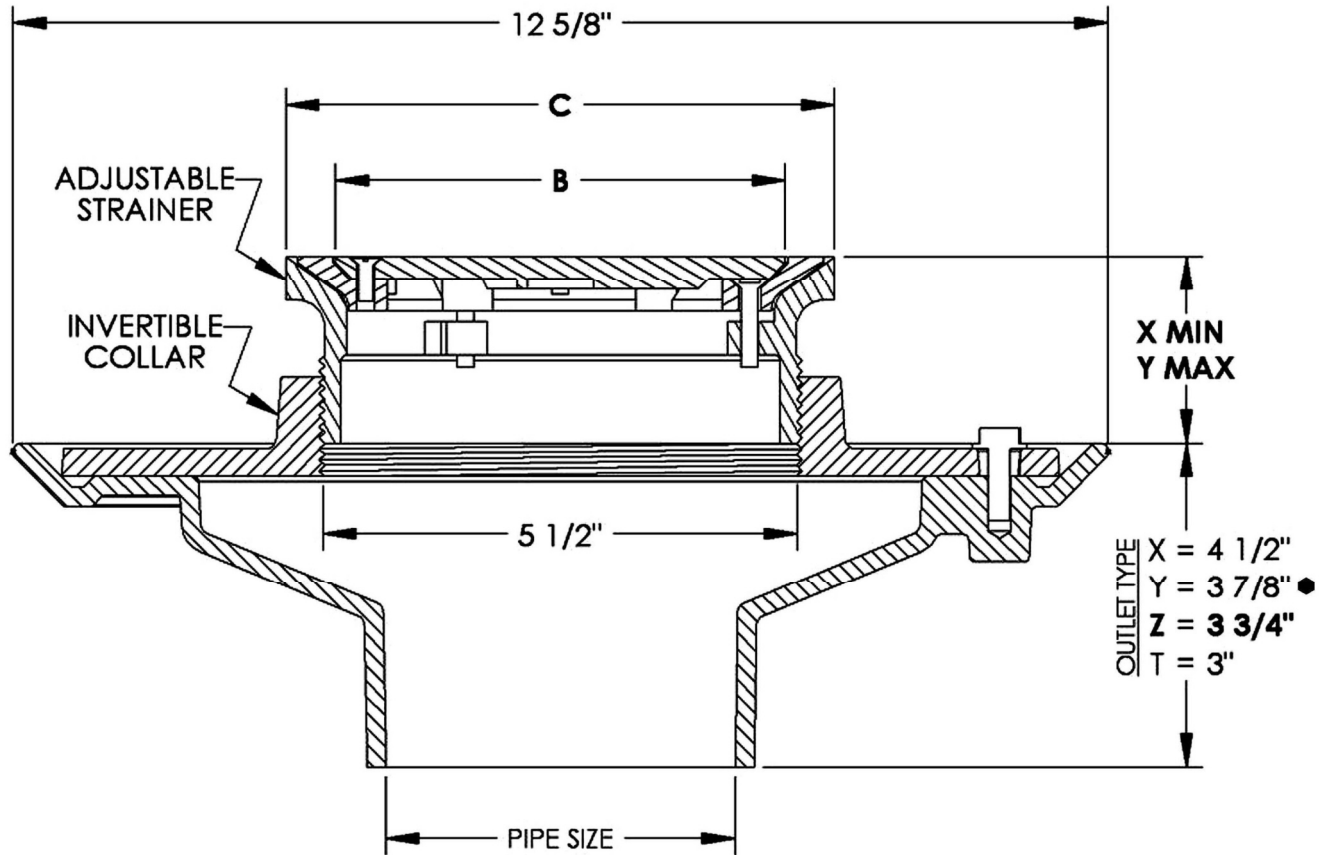

STRAINER	B	C	X	Y	FREE AREA	PIPE SIZE
-6AD	6	6-1/4	1-1/8	2-3/4	10.4	2"
-9AD	9	9-3/4	1-1/8	2-5/8	16.5	3"
						4"

- 2 BRONZE ADJUSTABLE STRAINER
- 66 NO-HUB SIDE OUTLET
- 92 GALVANIZED CAST IRON PARTS
- VP SECURED GRATE, VANDAL-PROOF SCREWS

- T THREADED OUTLET
- X INSIDE CAULK OUTLET
- Y HUB OUTLET WITH GASKET ●
- Z NO-HUB SPIGOT OUTLET

DRAWING No.

**A-13987-K**

**JOSAM COMPANY**  
MICHIGAN CITY, INDIANA

NOTES: