

Class 150 Ductile Iron Body Swing Check Valves

Raised Face Flanges • Bolted Bonnet • Bronze Trim

285 PSI/19.7 bar non-shock cold working pressure to -20°F to 100°F/-29°C to 38°C*

Maximum working temperature 450°F/232°C at 185 PSI/12.6 bar

150 PSI/10.3 bar saturated steam to 366°F/186°C

CONFORMS TO MSS SP-136

MATERIAL LIST

PART	SPECIFICATION
1. Bolt	Steel ASTM A307
2. Identification Plate	Aluminum
3. Bonnet	Ductile Iron ASTM A395
4. Body Gasket	Synthetic Fibers
5. Nut	Steel ASTM A563
6. Side Plug	Brass ASTM B584 C84400
7. Hanger Pin	Brass ASTM B371 C69430/C69400
8. Hanger	Ductile Iron ASTM A536
9. Disc ¹	Brass ASTM B584 C84400
10. Seat Ring	Brass ASTM B584 C84400
11. Disc Nut	Brass ASTM B371 C69430/C69400
12. Body	Ductile Iron ASTM A395
13. Disc Bolt ¹	Brass ASTM B371 C69430/C69400

¹2"-4" bronze disc

¹5"-12" ductile iron disc with bronze face ring and disc bolt



F-938-31
Flanged-Raised Face

DIMENSIONS—WEIGHTS—QUANTITIES

Size	Dimensions										Weight	
	A		B		D		E		Lbs.	Kg.		
In. mm.	In. mm.	In. mm.	In. mm.	In. mm.	In. mm.	In. mm.	In. mm.					
2 50	8.00 203	3.94 100	6.00 152	.63 16	24 11							
2½ 65	8.50 216	4.50 114	7.00 178	.69 17	35 16							
3 80	9.50 241	5.13 130	7.50 191	.75 19	47 21							
4 100	11.50 292	6.13 156	9.00 229	.94 24	81 37							
5 125	13.00 330	6.81 173	10.00 254	.94 24	100 45							
6 150	14.00 356	8.00 203	11.00 279	1.00 25	146 66							
8 200	19.50 495	9.44 240	13.50 343	1.13 29	255 116							
10 250	24.50 622	12.06 306	16.00 406	1.19 30	426 193							
12 300	27.50 699	16.13 410	19.00 483	1.25 32	660 299							

Lever and Weight/Spring Options available only in 3", 4" and 6". (see page 102)

Note: On pump discharge, the preferred check valves are:

- inline, spring assisted, center-guided, lift checks
- spring assisted twin (double) disc
- swing design with lever and weight or lever and spring

Install 5 pipe diameters minimum downstream from pump discharge or changes in direction to avoid flow turbulence. Flow straighteners may be required in extreme cases.

NIBCO® Check Valves may be installed in both horizontal and vertical lines with upward flow or in any intermediate position.

WARNING: Do not use for Reciprocating Air Compressor Service.

♦ For detailed Operating Pressure, refer to Pressure Temperature Chart on page 114.



WARNING: This product can expose you to chemicals including lead, which is known to the State of California to cause cancer and birth defects or other reproductive harm. For more information go to www.P65Warnings.ca.gov.

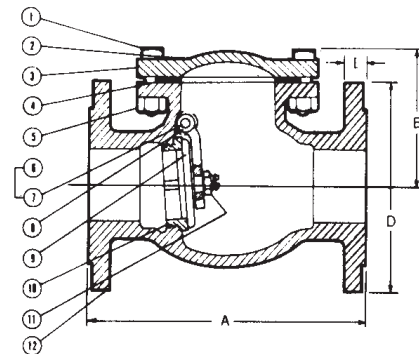

F-938-31
Flg x Flg

Visit www.nibco.com for current Chem-Guide and galvanic potential in piping systems information.