

## WIDESPREAD LAVATORY SET INSTALLATION INSTRUCTIONS

Model No: 2030

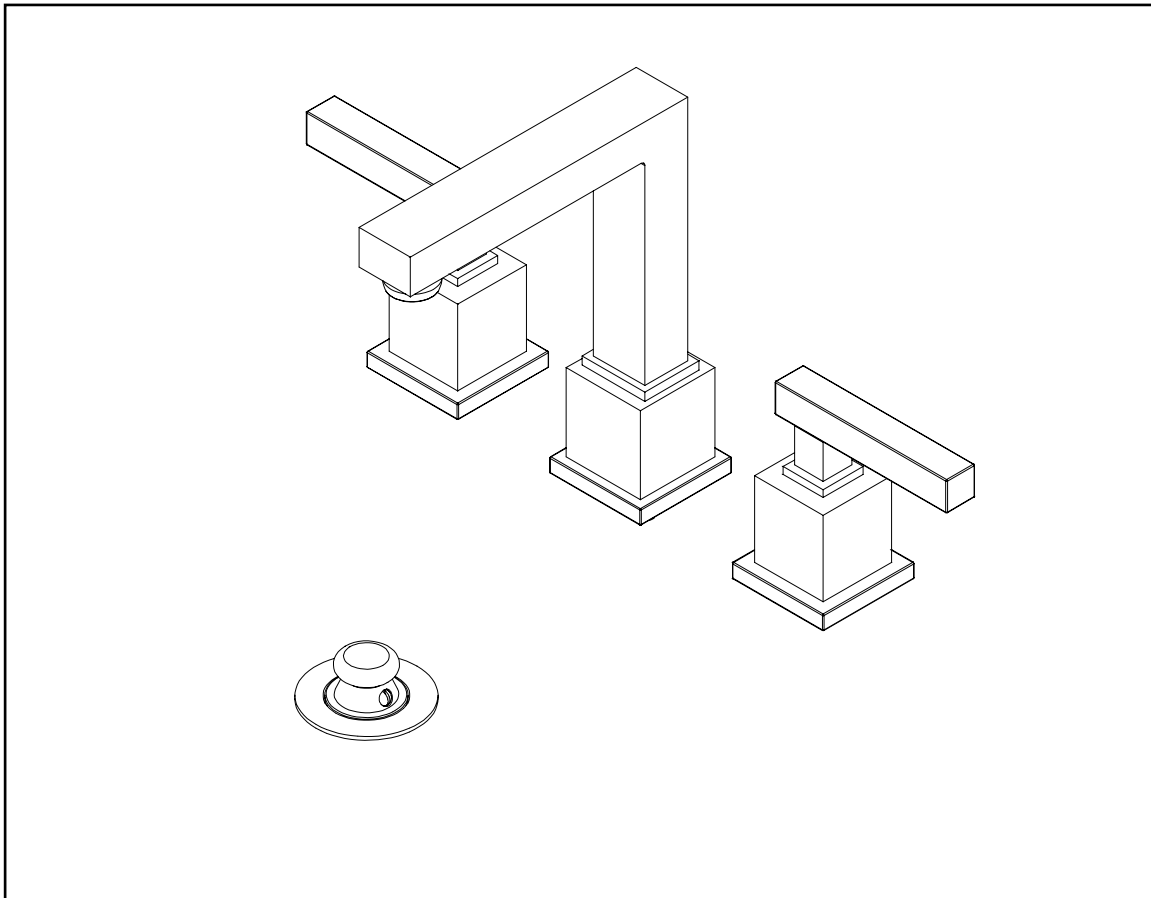

**Congratulations on the purchase  
of this Newport Brass product,  
an excellent choice, that will give you  
years of quality service and enhance  
the look and style of your home.**

## Recommended Installation by a Professional Plumbing Contractor

Note: The use of petroleum base plumbers putty on our products will nullify the warranty. We recommend the use of clear silicone sealing materials. Minimum deck thickness is 5/8". Recommended deck hole Ø1.38.

1. Insert SHANK (2) and HOSES (4), one at a time, through base ESCUTCHEON (3), O-RING (7) and sink hole. From underside of sink mounting GASKET (5) and CRESENT (6) and mounting NUT (8) onto spout SHANK (2). Align SPOUT (1) and secure into place by tightening mounting NUT (8). See Figure 1.
2. Place the plastic flange NUT (1) and fiber WASHER (2) onto valve BODY (3). Insert valve BODY (3) through sink hole from underside of sink. Place additional WASHER (4) and brass flange NUT (5) onto upper position of valve BODY (3). Valve BODY (3) should extend 2-1/2" above mounting surface. Secure into place by tightening lower flange NUT (1) to 20 ft.lbs. See Figure 2.
3. Connect larger coupling NUT (4) to outlet of each valve BODY (3). Hand tighten and secure each connection with a wrench 1/4 turn. Connect water supply to VALVE BODIES(1) with one of the three following types of risers:  
NOTE: SUPPLY RISERS ARE NOT INCLUDED - SOLD SEPARATELY
  - a. 1/2" IPS flexible riser, discard rubber NOSECONE (11), friction WASHER (12) and coupling NUT (13).
  - b. 3/8" or 1/2" O.D. bullnose riser, place friction WASHER (12) and coupling NUT (13) onto bullnose riser.
  - c. 1/2" O.D. copper riser, place coupling NUT (13), friction WASHER (12), and rubber NOSECONE (11) onto end of copper riser. See Figure 3. Use adjustable wrench to tighten connections. Do not over tighten and take care not to kink copper supply when bending. Use a tube bender and cutter to properly adjust copper supply. Turn VALVE STEM (3) to OFF position.
4. Attach ESCUTCHEON (14), BONNET (15), escutcheon NUT (14a) to cartridge. Any adjustments for rotational alignment must be made to the valve body - not to the cartridge. (Note: Allow minimum spacing between HANDLE (16) and escutcheon NUT (14a) to prevent damage to the surface finish.) Secure HANDLE (16) into place with setscrews. See Figure 4.
5. Place flange NUT (17), steel WASHER (18), concave WASHER (20), or based on sink configuration, rubber WASHER (19), on TAILPIECE (21). Insert through drain hole from underside of sink basin. Thread TAILPIECE (21) to flange/stopper ASSEMBLY (22). Note: Recommended to add a clear silicone adhesive between FLANGE (22) and sink basin to seal. Tighten flange NUT (17) to secure drain in place. Attach TAILPIECE (21) to p-trap drain (not included). See Figure 5.
6. Remove AERATOR (23) from spout, turn on water supply, and flush both valves until water is clear. Check for leaks and make any final adjustments required. Re-attach AERATOR (23) to the spout. See Figure 4.

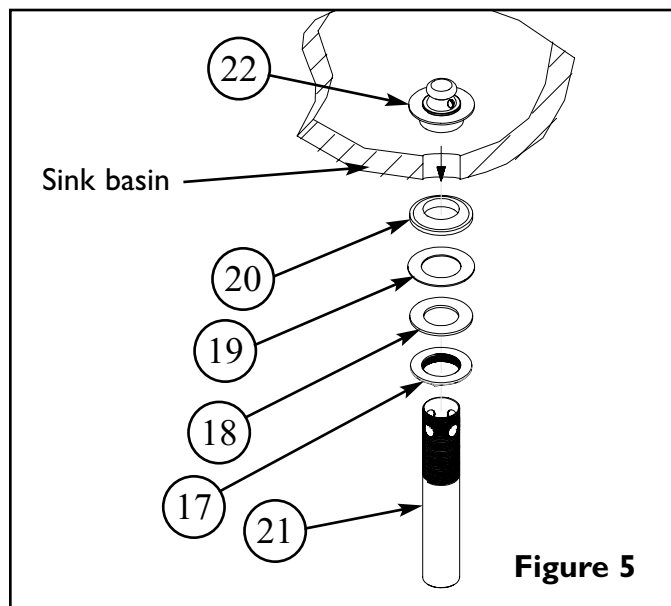
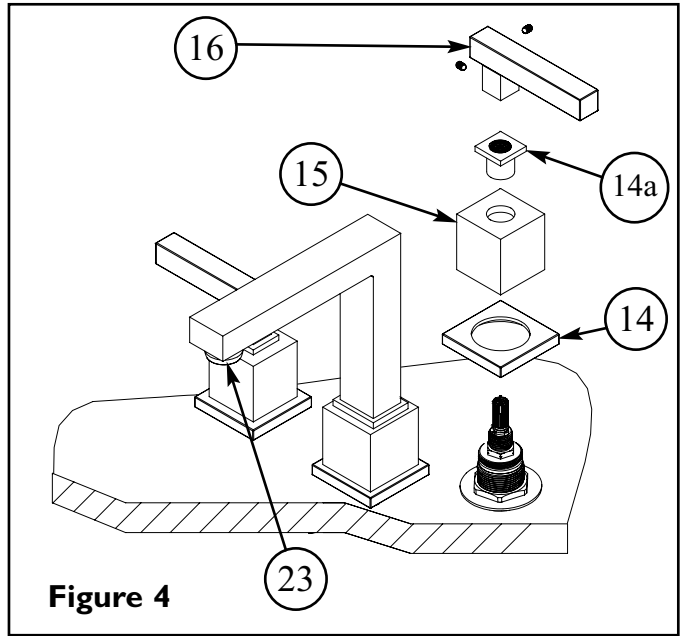
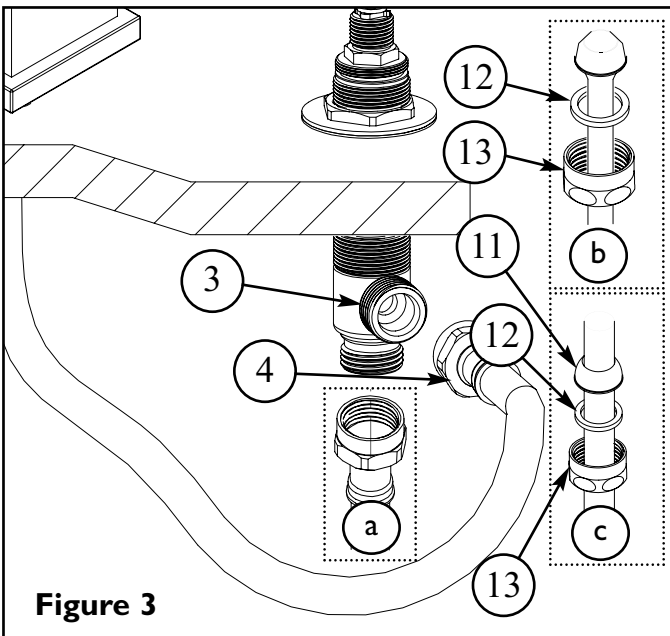
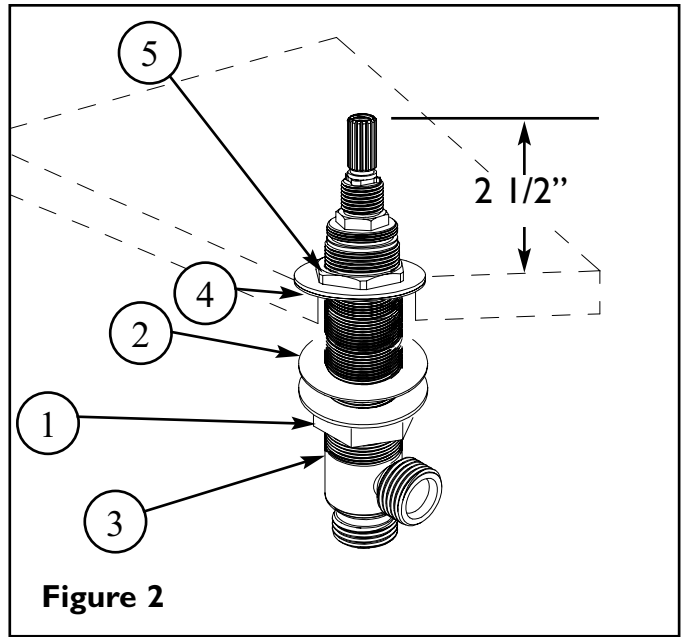
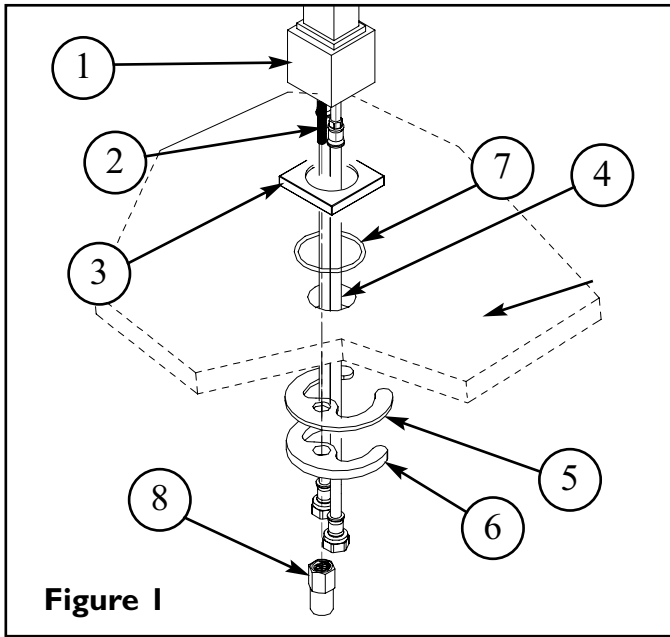

## LIMITED WARRANTY

Brasstech, Inc. warrants to the original consumer residential purchaser ("Original Purchaser") that if a product in its; Newport Brass®, Brasstech®, Motiv®, Plumbtrim® or GINGER® lines of products ("Product") is confirmed upon inspection to be defective in materials or workmanship during the warranty periods described below, Brasstech, Inc. will, at its option, either repair or replace the Product with a similar current model of the Product. If repair or replacement is not commercially practical or cannot be made in a timely manner, then Brasstech, Inc. will provide a refund for the Product.

## WARRANTY PERIODS AND COVERAGE PRODUCT FINISHES

- PVD and Polished Chrome (26) finishes on Products other than Drains and Shower rods are warranted as long as the Original Purchaser owns their home.
- "Living" finishes and Gold or Silver finishes, have no warranty\*. These include 03W, 03N, 08W, 24, 24S, 25 & 25S.
- Shower rods, porcelain parts and glass parts have no finish warranty.
- All other finishes are warranted for ten (10) years from date of purchase by the Original Purchaser.

## DRAIN FINISHES

- Polished Chrome (26) and PVD finishes on kitchen, bath or lavatory drains of all types ("Drains") are warranted for one (1) year from date of purchase by the Original Purchaser.
- All other Drain finishes have no warranty.

## FUNCTIONALITY

- All Product parts except valves are warranted for ten (10) years from date of purchase by the Original Purchaser.
- Ceramic disc valves for the lavatory faucet, tub/ shower and roman tub are warranted for as long as the Original Purchaser owns the home.
- All other valves (balance pressure, thermostatic, etc.) are warranted for one (1) year from date of purchase by the Original Purchaser.
- Lights have no functional warranty. Soap / Lotion pump mechanisms are warranted for one (1) year from date of purchase by the Original Purchaser.
- Shower rods, porcelain parts and glass parts have no functional warranty.

## EXCLUSIONS FROM COVERAGE

- This Warranty does not cover labor charges or associated costs for, or damages occurring during the removal, transportation, return or installation of Products or replacement Products.
- This Warranty does not cover damage or defects due to normal wear and tear, misuse, abuse, hard water, improper storage, improper handling, improper maintenance\*\*, improper installation\*\*\* or uses other than normal household usage\*\*\*\*.
- This warranty is non-transferable.
- Products sold to customers for use as display items are not meant for resale and are not covered under any functional or finish warranty.

## LIMITATIONS ON REMEDIES

In no event will Brasstech, Inc. be liable for incidental or consequential damages (such as labor charges), whether based on breach of express or implied warranty, breach of contract, negligence, strict liability or any other legal theory. Some states do not allow the exclusion or limitation of incidental or consequential damages, so, the above limitation or exclusion may not apply to you. Any implied warranties, including the implied warranties of merchantability and fitness for a particular purpose, are limited to the duration of this written warranty. Some states do not allow limitations on how long an implied warranty may last, so the above limitation may not apply to you.

## WARRANTY SERVICE

To obtain service under this Warranty, please contact your Product dealer. If you are unable to locate your dealer, please call 949-417-5207 or access the Brasstech, Inc. website at [www.brasstech.com](http://www.brasstech.com). Proof of purchase, such as the original receipt, is required for the dealer to issue credit to the consumer. The dealer must be an authorized dealer and the product must be purchased in the original manufacturer's packaging (display items excluded).

## STATE REMEDIES

This Warranty gives you specific legal rights, and you may have other rights which vary from state to state.

## PRODUCT CARE

Simple care is all that is needed in maintaining this product. Abrasive cleansers, detergents and silver or brass polish may result in damage to the finish and therefore should not be used. To clean, simply wipe with a soft, water dampened cloth. Ginger hand, deck and wall shower sprays feature easy-cleaning jets. The jets should be cleaned periodically by rubbing your thumb or a damp cloth across the jets to loosen mineral deposits. Run the shower spray briefly to purge the loosened deposits.

### \* UNCOATED AND LIVING FINISHES

Uncoated and Living finishes such as Polish Brass Uncoated (03N) and living finishes such as Weathered Brass (03W) and Weathered Copper (08W), do naturally weather and change color over time. Living and uncoated finishes are not warranted.

### \*\* MAINTENANCE

Proper maintenance is required to preserve all finishes. Do not use any abrasive cleaners, alcohol, ammonia, detergents, or brass or silver polish on the Products. For complete care requirements and recommendations, please visit our website at [www.brasstech.com](http://www.brasstech.com).

### \*\*\* PROPER INSTALLATION

Products must be installed in accordance with the manufacturer's installation instructions supplied with the Products. For example, pipes must be flushed before faucet installations, because solder and other debris may damage ceramic discs. You may also call 949-417-5207 for copies of the installation instructions. Many of our installation instructions are also available on our website, [www.brasstech.com](http://www.brasstech.com).

### \*\*\*\* COMMERCIAL PURCHASERS

Brasstech, Inc. extends the above limited warranty to purchasers of Products for industrial, commercial and business use upon the same terms and conditions and exclusions applicable to residential purchasers, except that the finish and functionality warranty periods are reduced to a period of one (1) year from the date of purchase. ADDITIONALLY, with respect to commercial purchasers, all implied warranties, including the implied warranties of merchantability and fitness for a particular purpose are excluded and disclaimed.

(949)417-5207

NWP-2030

Santa Ana, Ca. 92705  
[www.brasstech.com](http://www.brasstech.com)

06/18/2010