

Feature

EPDM hose with stainless steel braiding
 Swivel end x male threaded fixe end (ASME B1.20.1 - NPT)
 MNPT, FNPT, and Solder options available for swivel end

Working conditions:
 From 23°F to 200°F (Peaks up to 230°F)

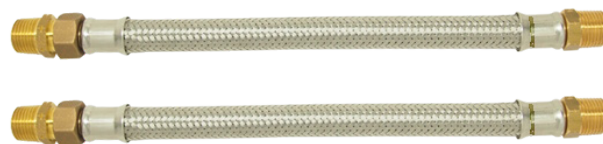

Sizes	Max. PSI	Burst Pressure
½" - 1¼"	350	1050
1½" - 2"	300	900

Material

	Part	Material	Specification
1	Nut	Brass	C37700
2	Insert	Brass	C37700
3	Connector	Stainless Steel	304SS
4	Inner pipe	EPDM	EPDM
5	Braided hose	Stainless Steel	304SS
6	Insert MNPT	Brass	C37700
7	Gasket	EPDM Perox	EPDM Perox
8	Nipple	DZR Brass	C35330

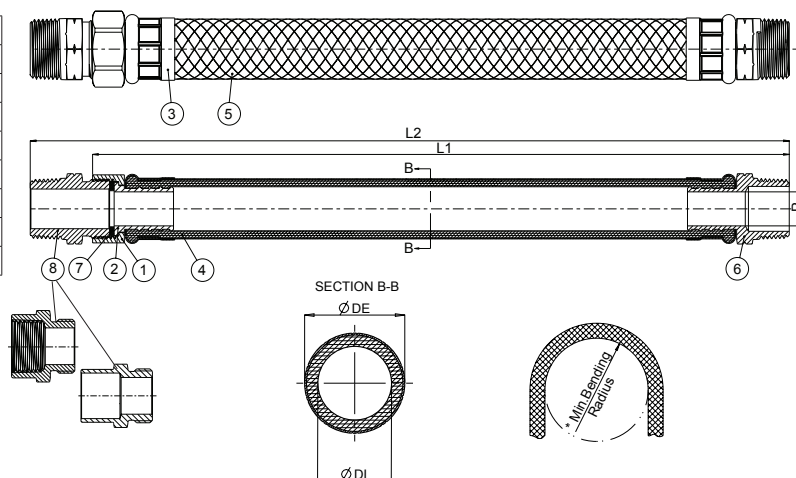

Dimension, Weight

L1 = 12 inch

Size	L2* [in]	P [in]	DI [in]	DE [in]	Wt. [lb]	Min. Bending R
½"	13.03	0.37	0.51	0.75	0.54	1.77
¾"	13.19	0.59	0.77	1.04	0.89	2.95
1"	13.35	0.75	0.98	1.32	1.53	3.54
1¼"	13.43	1.02	1.26	1.73	2.57	4.72
1½"	13.62	1.26	1.57	2.05	3.48	5.91
2"	13.70	1.61	2.01	2.52	5.14	7.09

L1 = 18 inch

Size	L2* [in]	P [in]	DI [in]	DE [in]	Wt. [lb]	Min. Bending R
½"	19.06	0.37	0.51	0.75	0.67	1.77
¾"	19.21	0.59	0.77	1.04	1.09	2.95
1"	19.37	0.75	0.98	1.32	1.75	3.54
1¼"	19.45	1.02	1.26	1.73	3.07	4.72
1½"	19.65	1.26	1.57	2.05	4.04	5.91
2"	19.72	1.61	2.01	2.52	5.89	7.09

L1 = 24 inch

Size	L2* [in]	P [in]	DI [in]	DE [in]	Wt. [lb]	Min. Bending R
½"	25.35	0.37	0.51	0.75	0.74	1.77
¾"	25.51	0.59	0.77	1.04	1.29	2.95
1"	25.67	0.75	0.98	1.32	2.02	3.54
1¼"	25.75	1.02	1.26	1.73	3.53	4.72
1½"	25.94	1.26	1.57	2.05	4.54	5.91
2"	26.02	1.61	2.01	2.52	6.55	7.09

L1 = 36 inch

Size	L2* [in]	P [in]	DI [in]	DE [in]	Wt. [lb]	Min. Bending R
½"	37.05	0.37	0.51	0.75	0.96	1.77
¾"	37.20	0.59	0.77	1.04	1.68	2.95
1"	37.36	0.75	0.98	1.32	2.61	3.54
1¼"	37.44	1.02	1.26	1.73	4.59	4.72
1½"	37.64	1.26	1.57	2.05	5.65	5.91
2"	37.72	1.61	2.01	2.52	7.87	7.09

* Refers to MNPT x MNPT