

***** ATTENTION *****

**PLEASE REMOVE THE
RIGHT SIDE BAFFLE
FILTER TO LOCATE YOUR
NEW REMOTE CONTROL.**



INSTALLATION INSTRUCTIONS & USE & CARE GUIDE

Trade-Wind® 3000 Slim Line
Series Range Hoods

3000 Series

Model	Width(in.)	CFM
30303RC	30"	390
30363RC	36"	390
30423RC	42"	390

390CFM Code Compliant



CONTENTS:

- Part 1 - Planning the Installation
- Part 2 - Electrical Connection
- Part 3 - Direction of Vent and
Securing The Hood
- Part 4 - Use & Care

Before beginning installation, please thoroughly read and become familiar with these instructions. Installation and service must be completed by a qualified installer. Failure to properly install this product may void the warranty.

Installer: Please leave Installation Instructions with the range hood owner.

Owner: Please keep Installation Instructions for local electrical inspector's use and for future reference.



WARNINGS: Instructions must be followed carefully to avoid personal injury.



IMPORTANT: Must be followed carefully to avoid damage or incorrect installation.



TIPS: Contain helpful information to facilitate installation.

READ AND SAVE THESE INSTRUCTIONS



WARNING! TO REDUCE THE RISK OF FIRE, ELECTRICAL SHOCK, OR INJURY TO PERSONS OBSERVE THE FOLLOWING:

- Use this unit only in the manner intended by the manufacturer. If you have any questions, please contact the manufacturer at the address or telephone number listed in the warranty.
- Before servicing or cleaning unit, switch power off at service panel and lock service panel and/or the service disconnection means to prevent power from being switched on accidentally. When the service disconnecting means cannot be locked, securely fasten a prominent warning device, such as a tag to the service panel.



CAUTION -- For general ventilating use only. Do not use to exhaust hazardous or explosive materials and vapors.



WARNING – TO REDUCE THE RISK OF A RANGE TOP GREASE FIRE:

- a) Never leave surface units unattended at high settings. Boilovers cause smoking and greasy spillovers that may ignite. Heat oils slowly on low or medium settings.
- b) Always turn hood ON when cooking at high heat or when flambeing food (i.e. Crepes Suzette, Cherries Jubilee, Peppercorn Beef Flambe’).
- c) Clean ventilating fans frequently. Grease should not be allowed to accumulate on fan or filter.
- d) Use proper pan size. Always use cookware appropriate for the size of the surface element.



WARNING! TO REDUCE THE RISK OF INJURY TO PERSONS IN THE EVENT OF A RANGE TOP GREASE FIRE, OBSERVE THE FOLLOWING:

- a) SMOTHER FLAMES with a close-fitting lid, cookie sheet, or metal tray, then turn off the burner. BE CAREFUL TO PREVENT BURNS. If the flames do not go out immediately, EVACUATE AND CALL THE FIRE DEPARTMENT.
- b) NEVER PICK UP A FLAMING PAN—YOU MAY BE BURNED.
- c) DO NOT USE WATER, including wet dishclothes or towels. A violent steam explosion will result.
- d) Use an extinguisher ONLY if:
 - 1. You know you have a Class ABC extinguisher and you already know how to operate it.
 - 2. The fire is small and contained in the area where it started.
 - 3. The fire department is being called.
 - 4. You can fight the fire with your back to an exit.



Recommendations:

- 1. Consult a licensed ventilation contractor or qualified technician for proper installation of exhaust ducting. Locate the cooking area for minimum cross drafts-away from doors and windows, when possible.
- 2. Ducts must be of adequate size and duct runs should be as short as possible. Where turns are necessary, keep turning radius as large and as smooth as possible.
- 3. The ducting must be air tight. Use a minimum of 2 sheet metal screws at every duct joint. Then, seal the duct joints with high quality duct tape.
- 4. Do not use this unit with any solid-state speed control device.
- 5. This unit must be grounded.

INSTALLATION INSTRUCTIONS



WARNING – TO REDUCE THE RISK OF FIRE, ELECTRIC SHOCK, OR INJURY TO PERSONS, OBSERVE THE FOLLOWING:

- a) Installation work and electrical wiring must be done by qualified person(s) in accordance with all applicable codes and standards, including fire-rated construction codes and standards.
- b) Sufficient air is needed for proper combustion and exhausting of gasses through the flue (chimney) of fuel burning equipment to prevent back drafting. Follow the heating equipment manufacturer's guidelines and safety standards such as those published by the National Fire Protection Association (NFPA) and the American Society for Heating, Refrigeration and Air Conditioning Engineers (ASHRAE) and the local code authorities.
- c) When cutting or drilling into wall or ceiling, do not damage electrical wiring and other hidden utilities.
- d) Ducted fans must always be vented to the outdoors.



WARNING -- TO REDUCE THE RISK OF FIRE, USE ONLY METAL DUCTWORK.



CAUTION –To reduce the risk of fire and to properly exhaust air, be sure to duct air outside – Do not vent exhaust air into spaces with in walls or ceilings or into attics, crawl spaces, or garages.



CAUTION – To reduce the risk of fire and electric shock, install this range hood only with Integral Blower manufactured by Trade-Wind®.

PART 1 Planning the Installation



CAUTION:

1. For general ventilating use only. Do not use to exhaust hazardous or explosive materials and vapors.
2. To reduce the risk of fire and to properly exhaust air, the hood must be exhausted to outside air. Never exhaust into a wall, an attic or a concealed area in the building. This can create a potential hazard.
4. Consult a licensed ventilation contractor or qualified technician for proper installation of exhaust ducting.
5. Locate the cooking area for minimum cross drafts—away from doors and windows, when possible.
6. Ducts must be of adequate size and duct runs should be as short as possible. Where turns are necessary, keep turning radius as large and as smooth as possible.
7. The ducting must be air tight. Use a minimum of 2 sheet metal screws at every duct joint. Then, seal the duct joints with high quality duct tape.
8. Only use ductwork constructed of materials deemed acceptable by state, municipal and local codes.
9. Plan the installation so that all minimum clearances are met or exceeded. Dimensions shown provide minimum clearances, unless otherwise specified.

Dimensions: Range Hood

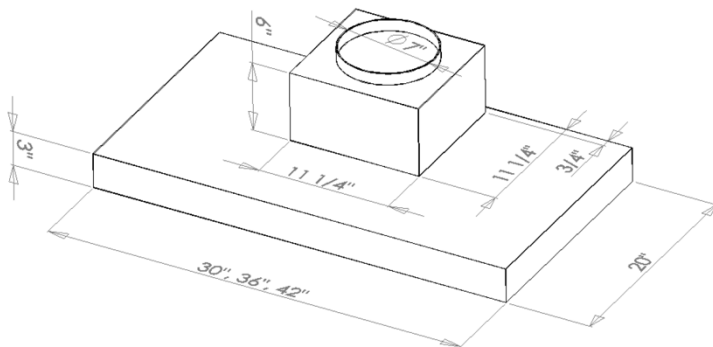

Duct Cover

(included for ceilings from 8' to 10')

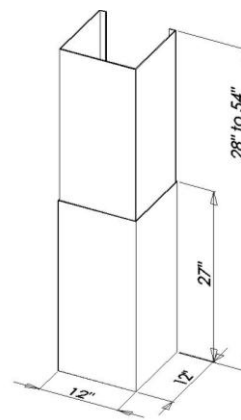

Duct Cover

(sold separately for ceilings from 10' to 12')

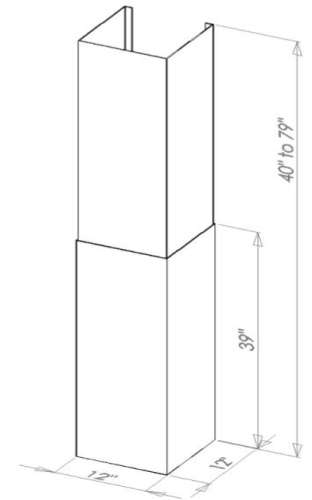

Dimensions			
Models	Width	CFM	Duct Opening
30303RC	30"	390	7"
30363RC	36"	390	7"
30423RC	42"	390	7"

*Please note that measurements provided reflect the bottom of the hood being 30" above the stove.

Optional Duct Covers
-DC3000-12 EXT KIT for 30303RC
30363RC
30423RC

NOTE: Use of duct cover is optional. Unit can be installed alone to be placed under any cabinet.

Mounting Instructions

- 1) Mounting bracket should be centered on wall in the position where the hood is to be installed. Mounting bracket should be leveled out to ensure proper installation of hood.
- 2) Installation of bracket should be exactly 8" from the bottom of the hood to the top of the bracket.

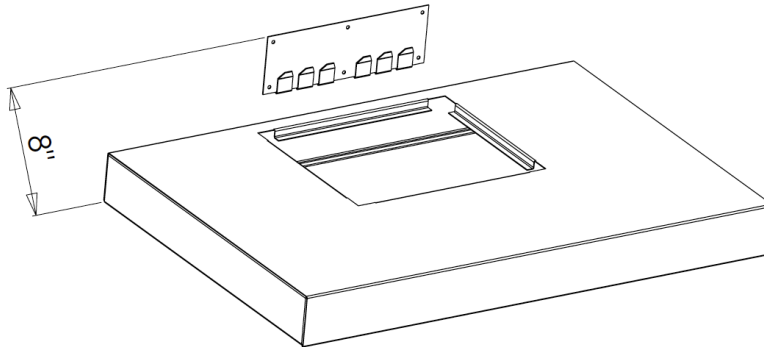

- 3) Attach the mounting bracket securely to the wall using 6 screws (not provided)
- 4) Holes are 3/16" in diameter.

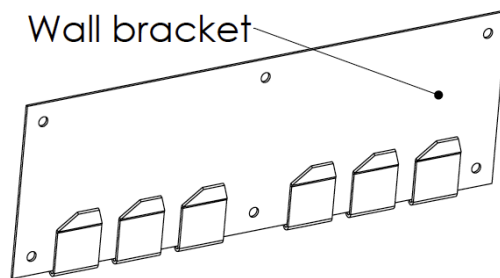

- 5) Once mounting bracket has been secured to the wall, lift the hood and proceed to slide the mounting harness onto the mounting bracket clips on the wall.

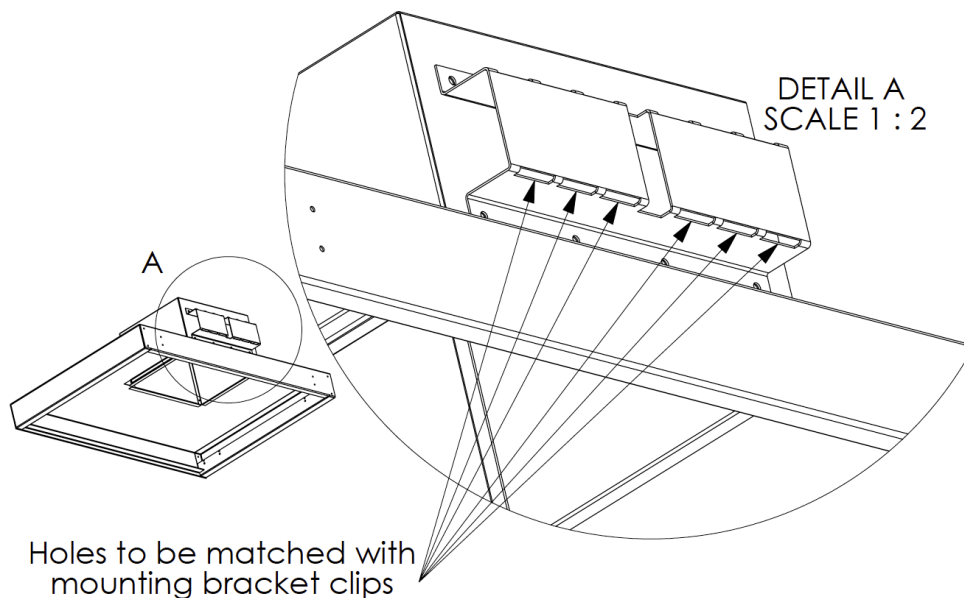

**** Ensure that both mounting bracket and harness are seated securely together.**



WARNING!

Following Are Manufacturer's Suggestions. Always Observe Local Building Codes.

Hoods installed in custom canopies constructed of combustible materials should be installed with the combustible material structure a minimum of 36" above the cooking surface. Hoods installed in custom canopies constructed of non-combustible materials, should be installed with the non-combustible material structure a minimum of 30" above the cooking surface. Follow all instructions regarding minimum safe clearances and installation location. Failure to do so may result in a safety hazard or fire. To reduce the risk of fire use only metal ductwork.

PART 2 Electrical Connection



WARNING!

Ensure that the power supply is disconnected before proceeding. Verify that the power supply matches the ratings found on the appliance data label before proceeding. The complete appliance must be properly grounded at all times when electrical power is applied. Do not ground the appliance with the neutral (white) house supply wire. A separate ground wire must be utilized. Failure to complete electrical connections properly may result in damaged or non-functional systems. Follow instructions carefully to ensure proper installation.

It is the owner's responsibility to ensure that a qualified person performs the electrical connection of this appliance. The electrical installation, including minimum supply wire size, must comply with the National Electric Code ANSI/NFPA 70-1990 (or latest revision) and local codes and ordinances. A copy of this standard may be obtained from:

National Fire Protection Association, 1 Batterymarch Park, Quincy, Massachusetts 02169-7471



INSTRUCTIONS: A 15 to 20 amp electrical service is recommended for proper electrical supply. Always observe local building codes. Always use a dedicated circuit.

Wire connections: (See Diagram Below) There are 3 wires on the front panel that require connection.

BLACK	120 VAC from electrical panel (usually black)
WHITE	Neutral from electrical panel (white)
GREEN	Ground from electrical panel (usually green)



CAUTION: The neutral wire (white) must only be connected to the white neutral wire coming in from the electrical panel.

House Electrical Panel

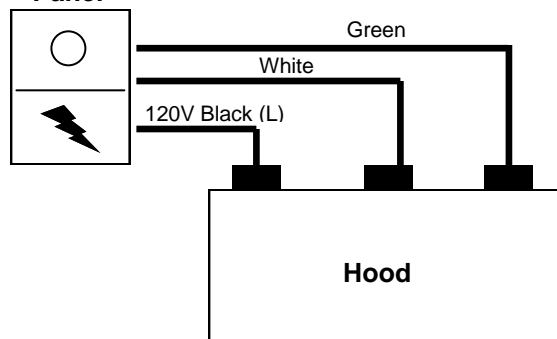

PART 3 Direction of Vent and Securing the Hood



MOUNTING HOLES: The Trade-Wind® 3000 Series range hood comes with x2 triangular mounting brackets that attach to the top of the hood and the wall to support the hood and minimize "rocking". There are x4 holes in each bracket that mount against the wall. If you can hit a stud with a lag bolt, only x2 per side should be sufficient. If toggle bolts are required, use all four holes per bracket. It may also be necessary to screw through the

actual back of the hood into the wall. No holes are provided since studs vary in location, so drill holes where studs are known to be (above the filters so screws do not show). NOTE: WHEN DRILLING THROUGH STAINLESS STEEL, IT IS PREFERABLE TO USE TITANIUM DRILL BITS. AVOID DRILLING THROUGH THE UL LABEL OR ANY ELECTRICAL COMPONENTS.

PART 4 Use and Care



FILTER REMOVAL

Each filter has two aluminum cylindrical knobs, one towards the rear and one towards the front. The front knob is actually a screw that holds the filter in place. The rear knob is only for grasping and is permanently connected to the filter. To remove the filter, simply unscrew the front knob counter clockwise until the knob comes out of the filter. Grasping the rear knob, push the filter backwards towards the rear of the hood until the front of the filter drops down. Grasping the filter, remove it from the rear by now pulling it forward.



OPERATING CONTROLS:

Always activate the ventilator when using cooking appliances. For best performance, turn on the blower a few minutes before starting to cook to establish an airflow pattern within the room. To use the electronic touch control, touch the button that corresponds to the desired speed. To turn off blower, touch the illuminated speed button again or the illuminated blower off control button. The electronic light control when touched comes on high; touch again for night light setting, touch again for light off.



WARNING!

Do NOT operate the blower / ventilator system without the filters in place, or with dirty, grease laden filters.



ENERGY SAVING TIPS:

Do not operate the blower at a speed higher than necessary to remove the cooking exhaust. Running at excessive speeds removes more air from the inside of the house that must be replaced by outside air. This may be especially costly when your home's heating or air conditioning system is in operation. Turn off the unit once the smoke and cooking odors have been eliminated. Clean filters and grease laden surfaces often to improve efficiency. Always use lids on cookware to retain heat and moisture. Minimize the amount of liquid used to cook food. Select cookware of proper size, material and construction for the cooking task being performed.



CARE & CLEANING:

Proper cleaning is necessary to maintain performance and appearance, while also ensuring safe operation. The frequency of cleaning should be adjusted according to the type and amount of cooking. Best results will be achieved by cleaning soiled components as soon as possible. Filters must be cleaned regularly.

The filters may be cleaned by hand washing in hot water using a mild detergent solution, or by placing them in a dishwasher. Locate holes on the sides of the filter. Put filter in dishwasher with holes facing up so detergent can enter filters. Dry the filters completely before using again. Rinse and dry with a soft lint-free cloth. Always wipe stainless steel surfaces with the grain. Never wipe across the grain. After cleaning, reinstall the filters carefully.

>> Most common scrubber type pads will scratch the hood.



CAUTION:

If a commercially available stainless steel cleaner is used, it is important to read the labels for chlorine compounds. Chlorine is a corrosive substance, DO NOT USE. Follow polish manufacturer's instructions.



LED LIGHT BULBS:

Trade-Wind® liners are designed for MR16/GU10 LED flood light bulbs. They can be purchased at most home or grocery stores. The bulbs provided with the unit are 3.5 watt, 350 lumen, and 3000K (color temperature).

Explaining the Remote

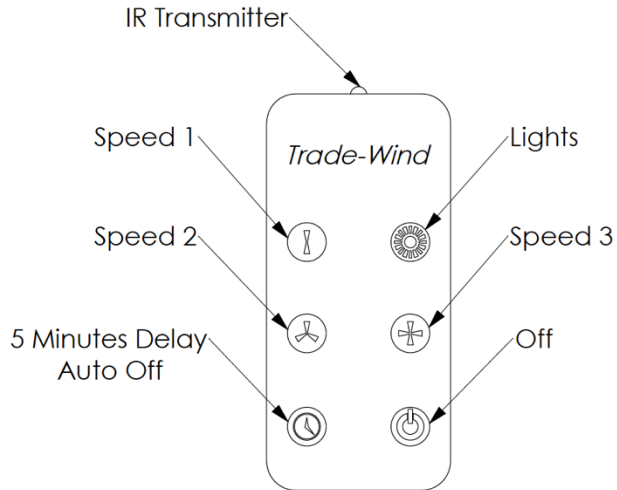

The diagram to the left shows all functions of the remote. Push the speed or light buttons once to turn on; push the same button a second time to turn off. You can use the "off" button to power off the lights and blower simultaneously.

The "5 minute delay auto off" button can be pressed when the blower is on at any speed. The blue light behind the speed button will blink showing that this feature has been activated. It will continue to blink for 5 minutes and then the blower will shut off automatically. If you press the "5 minute delay auto off" button again the blinking on the speed button stops and the blower has returned to manual mode.

If you would like to mount the remote to any surface near your range, Velcro pieces have been provided. Peel and stick one piece to back of remote, and the other to desired surface.

If battery in remote needs replacing, use a CR2025 watch battery. These are very common and easy to find. To access, look to the bottom end of the remote; push release to the right, and slide battery tray out.

Range of Remote Control

The infrared transmitter at the top of the remote must be pointed in the direction of the electronic control at the right front of your hood or liner. Range distance will vary depending on your installation, but see diagram below for approximate range area.

side view

front view

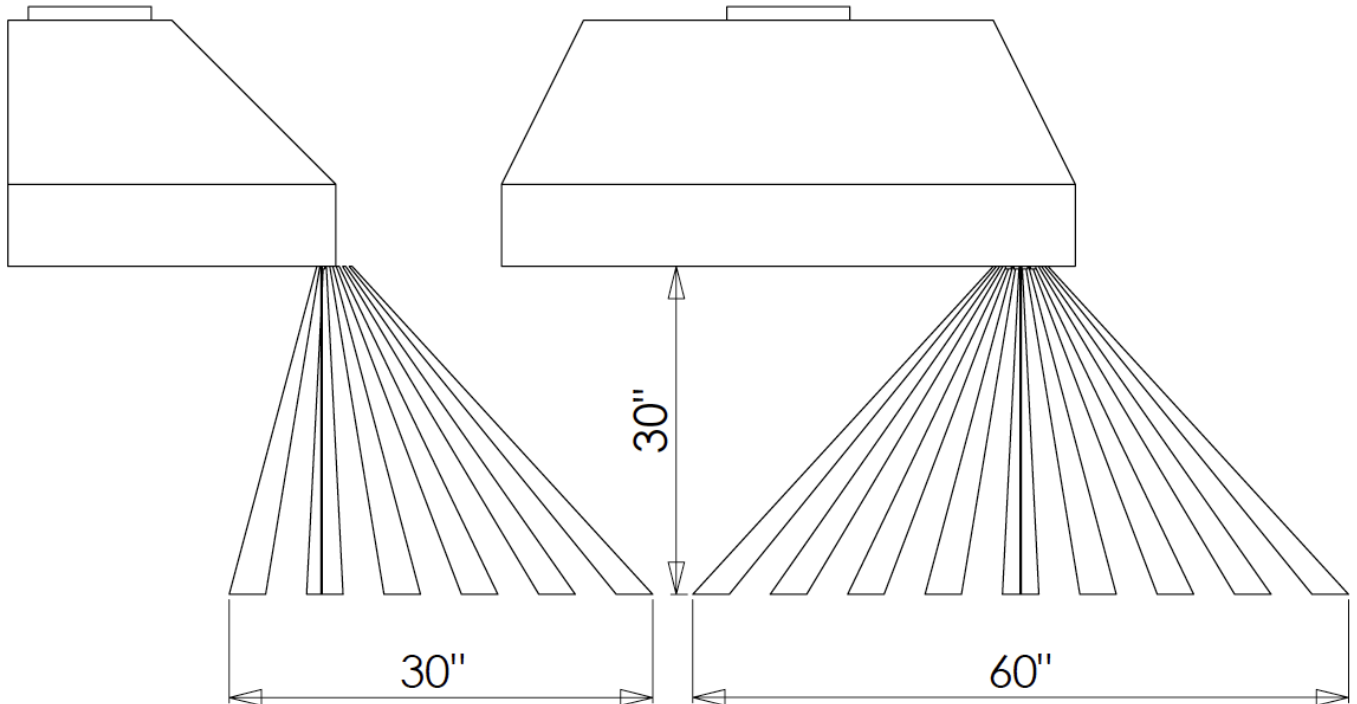



WARRANTY

TRADE-WIND Kitchen Ventilation Products

What IS Covered:

Trade-Wind Manufacturing, LLC[®] warrants its **Trade-Wind[®]** Kitchen Ventilation Products to the original user, to be free of defects in materials and workmanship for three (3) years from the date of purchase.

Trade-Wind Manufacturing, LLC[®] at its option, will repair or replace the complete unit or any defective component without charge. This warranty may be voided if any unauthorized service, alterations, or repairs are made to the product.

What is NOT Covered:

- Normal maintenance and service of any product that has been subject to misuse, negligence, accident, or installation inconsistent with the recommended **Trade-Wind[®]** Installation Instructions and **Trade-Wind[®]** Best Practices Guidelines.
- Product used other than for normal in-home use or products used outside of the United States and Canada.
- Damage to the product caused by accident, fire, flood, or other acts of God.
- Service calls to educate the customer in the proper use and care of the product, change fuses, or to reset the circuit breakers.
- Service calls to correct faulty installation, such as, performance issues relating to improperly sized ducting or restrictive roof caps is not covered and will by default be charged back to the Homeowner.
- Light bulbs are not covered under warranty.

Trade-Wind Manufacturing, LLC[®] disclaims and excludes any liability for implied warranties or for incidental or consequential damages wherever permitted by law. There are no implied warranties of merchantability or fitness for a particular use or purpose. This warranty gives you specific legal rights and you may also have other rights, which vary from state to state.

For Service: If you need service on your **Trade-Wind[®]** Kitchen Ventilation Product, visit our website at: www.t-wusa.com and click on the warranty tab. Fill out the simple form providing the model number, serial number, date of purchase, and brief description of the problem. Proof of purchase will also be required.

Warranty Revised 6/11/18

Trade-Wind Manufacturing, LLC[®] has a policy of continuous improvements and reserves the right to modify (at any time and without notice) any or all of its products, features, designs, components and specifications. *For exact dimensions, see the Installation Instructions included with each product.* Some features may be slightly different than shown on product literature.



For more information, please contact your Trade-Wind[®] Representative



800 West Grant Street, Phoenix, AZ 85007
1-800-955-5737
602-900-8500
t-wusa.com





Best Practices

Venting Installation Instructions for Range Hoods and Wood Hood Liners (All Models)

—*Addendum to Installation Instructions*—



IMPORTANT: Problems caused by improper installations are not covered by the manufacturer's warranty.



IMPORTANT: Undersized and improperly installed duct pipe and/or other ventilation components will cause excessive static pressure (air resistance), that may result in rattling, vibration and air buffeting noises, as well as inadequate ventilation.

1. Building Codes

Kitchen Hood Ventilators should be installed by qualified technicians familiar with state and local building codes.

2. Duct Pipe and Fittings (Elbows, Transitions, Roof & Wall Caps)

- a. Use round or rectangular rigid metal duct only. Where possible, use round duct as it creates the least amount of static pressure. DO NOT use flex duct.
- b. All duct sections and fittings (EXCEPT DAMPERS, per Section 4), should overlap and be connected with at least 3 – 4 equally spaced screws and wrapped tightly with 2 – 3 layers of Aluminum Foil Metal Duct Tape. This type of duct tape is more durable than traditional cloth duct tape. DO NOT use butt joints.
- c. For best air flow, elbows and pipe size transition fittings should not be directly connected to one another. Where possible, always include at least 15 inches of straight pipe between fittings.

3. Duct Pipe and Fitting Sizes. (See **Duct Sizing Chart and Area Calculations** Section for more detail)



IMPORTANT: DO NOT use either of the following duct pipe sizes or fitting sizes for any kitchen hood ventilator installations:

- 6" round duct pipe
- 3.25" x 10" rectangular x 6" round transitions
- 6" x 7" linear transitions



IMPORTANT: No portion of any length of duct pipe or fitting should be smaller than the discharge port of the ventilator. This is very important because any type of restriction anywhere in the ventilation system will cause increased static pressure (air resistance), that may result in rattling, vibration and air buffeting noises, as well as inadequate ventilation.

Example: For ventilator models with 3.25" x 10" discharge ports, no part of the roof cap or wall cap's air path should be smaller than 3.25" x 10" (32.5 square inches) or 7" round (38.5 square inches). See **Roof Caps and Wall Caps** section for more detail.

Exception: For some short duct runs inside walls framed with 2 x 4 studs, it is a common industry practice to transition a 7" round duct to a 3.25" x 10" rectangular duct. If space allows, it is best to use a 3.25" x 14" rectangular duct with a 3.25" x 14" x 7" transition.

Duct Runs – Length

- a. Configure the ventilation duct run to be as short and as direct to the outside as possible. Minimize the number of elbows and transition fittings used. Complex or long runs should be reviewed by a qualified installer.

- b. No portion of the ducting should be run so that the exhaust air flows downward. Since exhaust heat rises, forcing the air to flow downward will cause increased static pressure. As previously mentioned, improperly installed duct pipe will cause excessive static pressure (air resistance), that may result in rattling, vibration and air buffeting noises, as well as inadequate ventilation.
- c. Duct runs for 390 CFM ventilator models should not exceed 20 linear feet with two 90-degree elbows (or four 45-degree elbows), a damper and a roof or wall cap. Longer runs or additional elbows will result in decreased ventilation performance. Each 90-degree elbow is the equivalent of 8 linear feet of duct pipe; each 45-degree elbow is equivalent to 4 linear feet of duct pipe.
- d. Duct runs for 600 – 1200 CFM ventilator models should not exceed 35 linear feet with two 90-degree elbows and two 45-degree elbows, a damper and a roof or wall cap. Longer runs or additional elbows will result in decreased ventilation performance. Each 90-degree elbow is the equivalent of 6 linear feet of duct pipe; each 45-degree elbow is equivalent to 3 linear feet of duct pipe.
- e. Always run ventilator ducts to the outdoors. DO NOT terminate a duct into an attic, basement, garage, crawl space under a house, a chimney, other ducting or an enclosed room.

4. Dampers



IMPORTANT: DO NOT USE SCREWS TO ATTACH ANY TYPE OF DAMPER AS THE SCREWS MAY BLOCK THE DAMPER BLADES.



IMPORTANT: DO NOT USE MORE THAN ONE DAMPER IN THE VENTILATION SYSTEM. **NOTE:** Many styles of roof caps and wall caps have built-in dampers. See **Roof Caps and Wall Caps** section for more detail.

Always use carefully crafted, tightly wrapped Aluminum Foil Metal Duct Tape on all connections and physically view and test the damper blades to make certain they are opening and closing correctly. Make sure that the damper blades do not touch the duct walls and that there is no debris blocking the free movement of the damper mechanism. Common things to look for include screws protruding into the blade's path, overspray of paint, plaster and insulation. If using rectangular duct, be sure that all four sides of the duct are on the outside of the damper's start collar or frame.

a. 390CFM Models

390CFM models have a 7" round Ducting and Damper.

DO NOT USE SCREWS TO ATTACH THE DUCT TO THE DAMPER FRAME AS THE SCREWS MAY BLOCK THE DAMPER BLADE. ALWAYS use Aluminum Foil Metal Duct Tape on all connections and physically view the damper blade to make certain it is operating correctly. On ventilator installations designed to recirculate the exhaust air back into the kitchen, be sure to remove the aluminum damper blade before attaching the duct to the damper frame.

b. 600 – 1200 CFM Ventilator Models Damper in Roof Cap or Wall Cap

In ventilation systems utilizing a roof cap or wall cap **with** a built-in damper, do not install an additional in-line damper. Two dampers are unnecessary and will cause increased static pressure (air resistance), that may result in rattling, vibration and air buffeting noises, as well as inadequate ventilation.

In-line Damper (for ventilation systems utilizing a roof cap or wall cap **without** a built-in damper)

In cold weather areas, installing an "in-line" damper may be the preferred type of installation. This is because in-line dampers installed just above the perimeter of the heated space (the ceiling) will reduce the amount of cold air traveling down the duct into the heated space and into the kitchen through the ventilator.

In-line dampers must be installed so that the exhaust air flow will open the butterfly blades.

For **horizontal duct runs**, the in-line damper must be installed so that the hinge between the two

butterfly blades is **vertical**—the hinge pin must point up and down. Otherwise, because of gravity, the damper’s blades will not close and the damper will not prevent backdrafts.

For **vertical duct runs**, the in-line damper’s hinge will be **horizontal** (sideways), which is correct for vertical duct runs. Gravity will help close the damper blades after each use.

For **upward slanted duct runs**, the in-line damper’s hinge must point to the top and bottom sides of the duct. In his position, gravity will help close the damper blades after each use. Otherwise, because of gravity, the damper’s blades will not close and the damper will not prevent backdrafts.

5. Roof Caps and Wall Caps

The roof cap or wall cap is the termination point of the venting system that allows the exhaust air to exit to the outdoors. All sections of this fitting must have an equal or greater air path area than the ventilator’s discharge port. If any section of the roof cap or wall cap is smaller than the ventilator’s discharge port, the entire ventilation system will lose efficiency and the restriction will cause increased static pressure.



IMPORTANT: Even though the intake side of the roof cap or wall cap may be properly sized, roof caps or wall caps with built-in dampers must be made so that when the damper is fully open, the actual open area of the final air path is equal to or greater than the discharge port of the ventilator. Any undersized portion of a roof cap or wall cap will cause excessive static pressure that may result in rattling, vibration and air buffeting noises, as well as inadequate ventilation.

*****Roof caps and wall caps must have an integral bird screen.**

6. Attaching Duct to House Framework

The ventilation system should be attached to the framework in such a manner that the weight of the duct and fittings is supported with no stress on the duct joints, fittings or on the ventilator. All ducting should be attached so as to avoid any possible duct vibration from being transferred to the house’s framework.

7. Duct Sizing Chart and Area Calculations

Ventilator Discharge Port Types & Sizes		Duct Type Required	Duct Size (in Square Inches)	Minimum Discharge Size of Roofcap or Wallcap Outside Opening
6" Diameter, Round	28.3"	6" Round Metal Duct	28.3"	28.3"
7" Diameter, Round	38.5"	7" Round Metal Duct	38.5"	38.5"
8" Diameter, Round	50.25"	8" Round Metal Duct	50.25"	50.25"
10" Diameter, Round	78.5"	10" Round Metal Duct	78.5"	78.5"
3.25" x 10" Rectangular	32.5"	3.25" x 10" Rectangular Metal Duct	32.5"	32.5"

Calculating Square Inches of Various Duct Sizes & Types

ROUND DUCT					
Radius	x	Radius	x	3.1416	= Area (Sq. Inches)
	x		x		=
The “radius” is one-half the diameter of a round duct, e.g., ½ of a 10” round duct is 5”. 3.1416 is “Pi”, the “constant” used when calculating the area of a circle.					

RECTANGULAR DUCT or WALL/ROOF CAP				
Width	x	Depth	=	Area (Sq. Inches)
	x		=	