

VSL 400 SERIES

RANGE HOOD LINERS FOR REMOTE/IN-LINES

For those who need ventilation performance and desire the commercial style baffle filters, your VSL 400 Series Liner will exceed your expectations.

VSL400 SERIES

Experience...

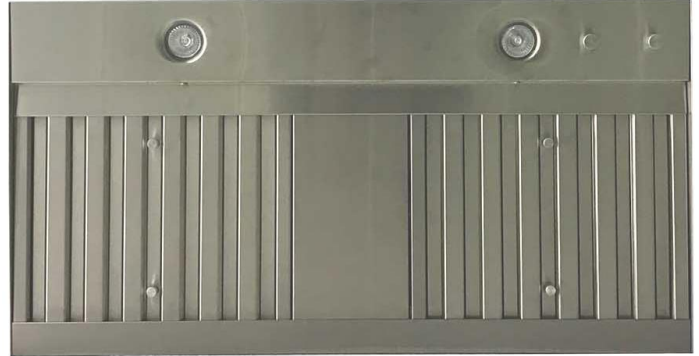

EASY CLEANING

- Dishwasher safe commercial baffle filters
- Leading edge design is easy to clean. Eliminates grease traps.
- No unsightly screws to clean around.

QUIET OPERATION

- Variable motor control reduces blower and air movement sound
- Large, stainless steel baffle filters reduce air movement sound
- Sound absorbing duct silencers, Neoprene[®] lined sound absorbing fast clamps & dampers available

ENDURING QUALITY

- In-line blowers deliver 836 CFM or 1266 CFM
- Commercial grade stainless steel (#304 grade with #4 brush finish) and galvanized steel construction
- Oversized baffle filters improve ventilation performance
- Two LED lights brighten cooking area; three on 448, 454, 460, & 472 models
- Performance tested by Energy Systems Laboratory at Texas A&M University

DISTINCTIVE LOW PROFILE DESIGN

- Style complements ALL custom and manufactured wood hood designs
- Metallic control knobs on all variable speed in-line blower models.
- Simplicity of design preferred by home owners

EASY INSTALLATION

- Remote blower models pre-wired for use with most in-line or exterior blowers
- Installs easily in standard size or custom built wood range hoods
- Wiring diagram label for simple electrical connection

VSL 400 SERIES RANGE HOOD LINERS FOR REMOTE/IN-LINES

Models Available (by Width)											
Pic	CFM	28 ³ / ₈ "	34 ³ / ₈ "	40 ³ / ₈ "	46 ³ / ₈ "	52 ³ / ₈ "	58 ³ / ₈ "	70 ³ / ₈ "	Sones	Control	Blower
A	-	VSL430BF	VSL436BF	VSL442BF	VSL448BF	VSL454BF	VSL460BF	VSL472BF	N/A	Variable	In-Line or Remote Mount Blower

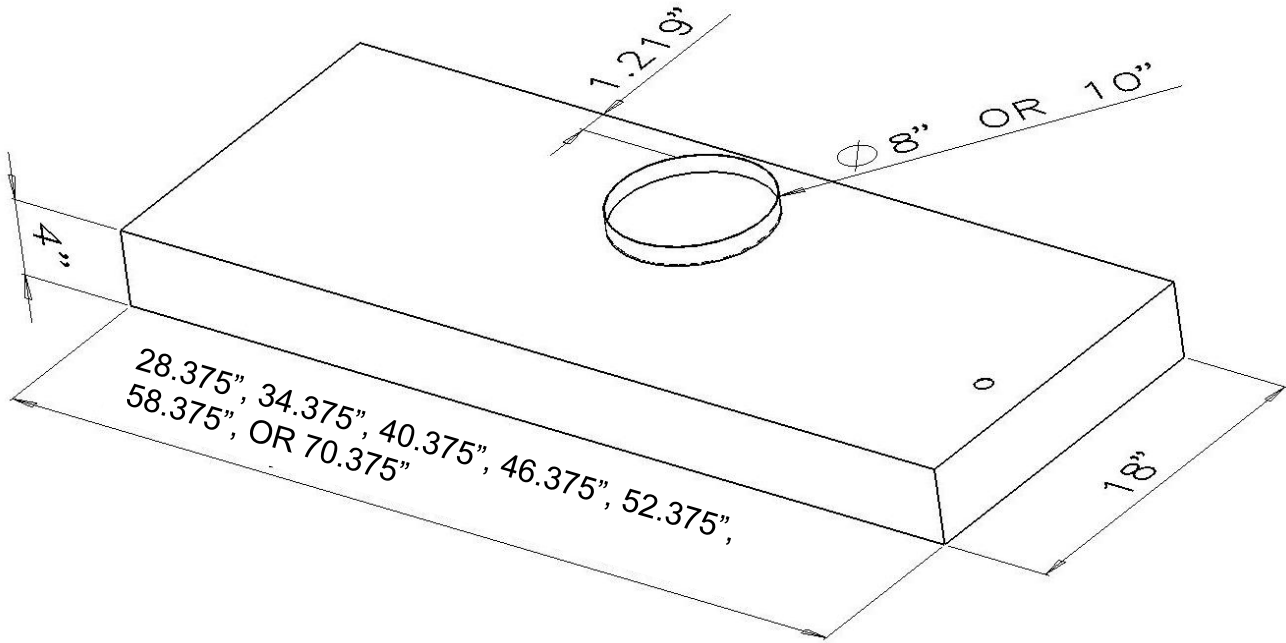

Notes:

- Center of electrical access is 7" from the front & 2 ¹/₂" from side of liner. Connection access is behind filters.
- Vent is 8" (models 430 & 436) or 10" (442, 448, 454, 460, & 472). Damper *not* included.
- Length & width cutouts should be ¹/₈" larger than above dimensions.

Trade-Wind Manufacturing, LLC has a policy of continuous improvements and reserves the right to modify (at any time without notice) any or all of its products, features, designs, components and specifications. For further information on installation and wiring, see the installation instructions included with the product or visit us on the web.

For more information please contact your dealer or your Trade-Wind® representative.



800 West Grant Street, Phoenix, AZ 85007
1-800-955-5737
602-900-8500
t-wusa.com

