



Model 350AR

Replacement Double Check Valve Assembly

Application

Designed for drop-in replacement of existing longer lay length assemblies without the need for additional spools or spacers, saving 2 to 6 hours of installation labor and up to 2 machine hours per backflow replacement. A custom sized grooved spool installed between the backflow body and downstream shut-off valve allows customer specified assembly lengths to be shipped directly from the factory. Designed for installation on potable water lines to protect against both backsiphonage and backpressure of polluted water into the potable water supply. The Model 350AR shall provide protection where a potential health hazard does not exist.

Standards Compliance

- ASSE® Listed 1015
- IAPMO® Listed
- CSA® Certified
- UL® Classified
- C-UL® Classified
- FM® Approved
- Approved by the Foundation for Cross Connection Control and Hydraulic Research at the University of Southern California
- Meets the requirements of NSF/ANSI 61*

*(0.25% MAX. WEIGHTED AVERAGE LEAD CONTENT)

Materials

Main valve body	Ductile Iron ASTM A 536
Access covers	Ductile Iron ASTM A 536
Coatings	NSF Approved electrostatic epoxy finish
Internals	Stainless steel, 300 Series NORYL™
Fasteners & Springs	Stainless Steel, 300 Series
Seal ring	EPDM (FDA approved)
O-ring	Buna Nitrile (FDA approved)



LEAD FREE



PATENT NO. 8,997,772

Options

(Suffixes can be combined)

- with flanged end NRS gate valves (standard)
- OSY - with flanged end OS&Y gate valves
- PI - Post Indicator gate Valve
- G - with grooved end OS&Y gate valves
- BG - with grooved end butterfly valves with integral supervisory switches
- BF - with flanged end butterfly valves with integral supervisory switches
- 509 - with AWWA C509 gate valves

Accessories

- Repair kit (rubber only)
- OS & Y GATE valve tamper switch (OSY-40)

Features

Sizes:	2 1/2", 3", 4", 6", 8", 10"
Maximum working water pressure	175 PSI
Maximum working water temperature	140°F
Hydrostatic test pressure	350 PSI
End connections - Flanged	ANSI B16.1 Class 125

*2 1/2" & 3" sizes use 4" body & reducer couplings

Dimensions & weights (do not include pkg.)

MODEL 350AR SIZE	WEIGHT WITH MAX. SPOOL LENGTH												
	WITH NRS GATES FLANGED		WITH NRS GATE VALVES GROOVED		OSY GATE VALVES FLANGED		OSY GATE VALVES GROOVED		BUTTERFLY VALVES FLANGED		BUTTERFLY VALVES GROOVED		
	in.	mm	lbs.	kg	lbs.	kg	lbs.	kg	lbs.	kg	lbs.	kg	
2 1/2	65	190	86	180	82	208	94	198	90	188	85	177	80
3	80	212	96	200	91	230	104	218	99	200	91	187	85
4	100	242	110	222	101	278	126	254	115	186	84	163	74
6	150	384	174	354	161	442	200	420	191	286	130	256	116
8	200	795	361	755	342	877	398	823	373	623	283	577	262
10	250	1087	493	1035	469	1183	537	1125	510	819	371	761	345

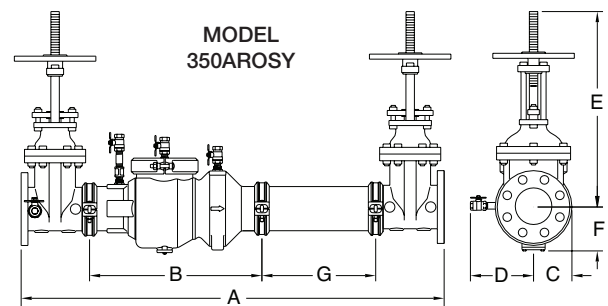

MODEL 350AR SIZE	DIMENSION (approximate)																												
	A WITH GATE VALVES				A WITH BUTTERFLY VALVES				B	C	D	E OS&Y OPEN		E OS&Y CLOSED		E NRS GATE		E BUTTERFLY VALVE		F	G SPOOL LENGTH								
	in.	mm	min	max	in.	mm	min	max				in.	mm	in.	mm	in.	mm	in.	mm		in.	mm	in.	mm	min	max	min	max	
2 1/2	65	37 1/8	47 1/8	943	1197	34 1/8	44 1/8	867	1121	20 1/8	511	4 1/2	114	7 1/4	184	17 3/4	451	15 3/8	391	11 1/2	292	8 1/4	210	6	152	2	12	51	305
3	80	38 1/8	48 1/8	968	1222	34 5/8	44 5/8	879	1133	20 1/8	511	4 1/2	114	7 1/4	184	20 1/4	514	17	432	12 3/4	324	8 1/2	216	6	152	2	12	51	305
4	100	40 1/2	62 1/4	1029	1581	35 3/4	57 1/2	908	1461	19 7/8	505	4 1/2	114	8	203	22 1/2	572	18 1/4	464	14 1/2	368	9	229	6	152	2 1/4	24	57	610
6	150	49 1/2	71 1/4	1257	1810	42 1/2	64 1/4	1080	1632	25 7/8	657	5 1/2	140	10	254	30 1/2	775	24 1/4	616	18	457	10 1/4	260	7	178	2 1/4	24	57	610
8	200	64 7/8	86	1648	2184	57 7/8	79	1470	2007	38 1/2	978	10	254	11	279	37	940	28 1/2	724	22 1/8	537	12	305	8 1/2	216	2 7/8	24	73	610
10	250	67 3/8	100 5/8	1711	2556	61 7/8	94 5/8	1572	2403	38 1/2	978	10	254	12	305	45 5/8	1159	34 3/4	883	24 3/4	626	13	330	8 1/2	216	2 3/4	36	70	914

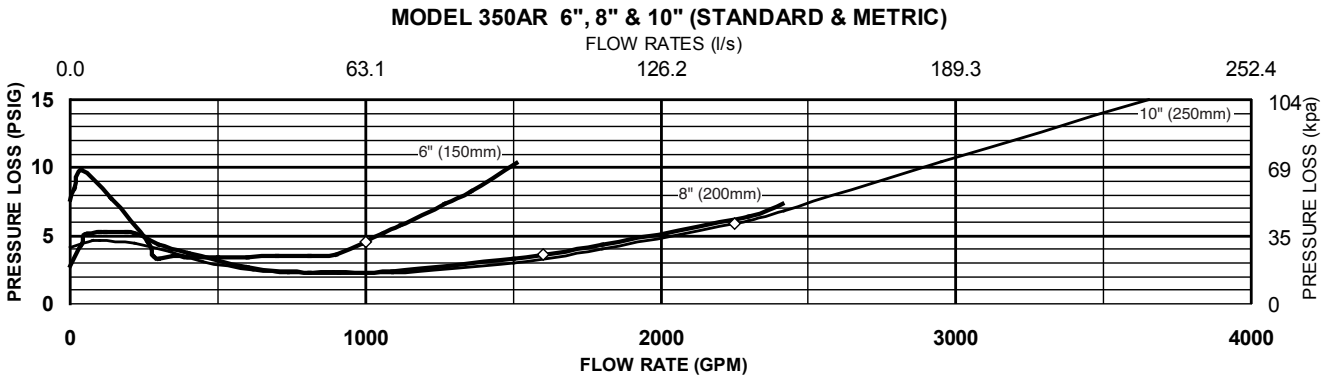
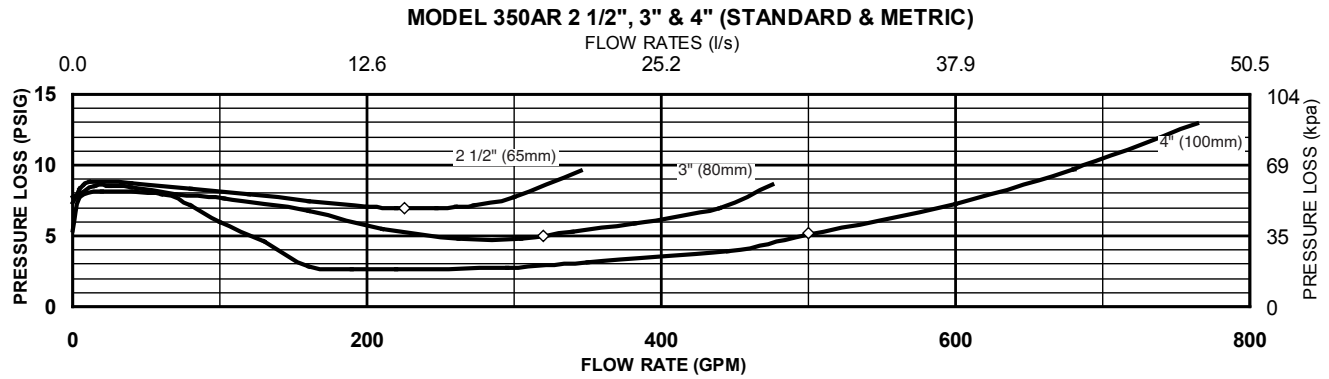

TYPICAL INSTALLATION

Local codes shall govern installation requirements. Unless otherwise specified, the assembly shall be mounted at a minimum of 12" (305mm) and a maximum of 30" (762mm) above adequate drains with sufficient side clearance for testing and maintenance. The installation shall be made so that no part of the unit can be submerged.

ORDER CONFIGURATION

- Exact in field measurements are required when ordering the assembly. Please have the assembly length ready when ordering.
 - All assemblies are custom made to order and all sales are final.
 - Lead time is approximately one week.
- Generic part number used for ordering:

X-350AR*-Y

where X= NOMINAL VALVE SIZE (212 REPRESENTS 2-1/2")
 Y= ASSEMBLY LENGTH SUFFIX: choose A-C from table at right (exact in field measurements must be given to customer service representative)
 *= ADDED OPTIONS (use suffixes designated in OPTIONS section on previous page)

EXAMPLE

To order a 4" Model 350 AR with OS&Y gate valves and an assembly length of 52 3/8", the part number would be 4-350AROSY-B.
 The length of 52 3/8" would be given to Customer Service.

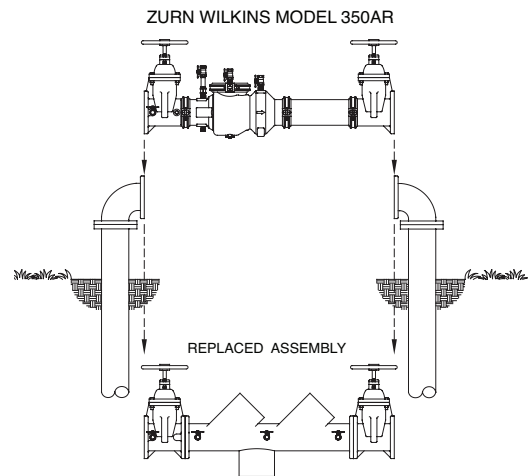

NPS	ASSEMBLY LENGTH SUFFIX					
	A		B		C	
	From	To	From	To	From	To
2-1/2"	34 1/8"	47 1/8"				
3	35 5/8"	48 1/8"				
4	35 3/4"	50"	50 1/16"	62 1/4"		
6	42 1/2"	59"	59 1/16"	71 1/4"		
8"	57 7/8"	74"	74 1/16"	86"		
10"	61 3/8"	77"	77 1/16"	89"	89 1/16"	100 5/8"

SPECIFICATIONS

The Double Check Backflow Prevention Assembly shall be certified to NSF/ANSI 61, ASSE® Listed 1015, and supplied with full port gate valves. The main body and access cover shall be epoxy coated ductile iron (ASTM A 536), the seat ring and check valve shall be NORYL™, the stem shall be stainless steel (ASTM A 276) and the seat disc elastomers shall be EPDM. The checks shall be accessible for maintenance without removing the device from the line. The Double Check Backflow Prevention Assembly used for all backflow replacements shall be a ZURN WILKINS Model 350AR.