

SHERLE WAGNER INTERNATIONAL

EGG TUB 0290TUB-XXXX



PRODUCT FEATURES

- o Carved from solid block of stone
- o Available in various marble and onyx
- o Hand carved detail
- o 2-1/2" drain diameter
- o 21" deep bathing area
- o Approximate 1900 lb (862 kg) total weight
- o Requires a free standing waste system with integrated over flow

AVAILABLE MARBLE

RSAU Rose Aurora
ARAB Arabescato
CARR Cararra
RUVI Ruvina

CAGR Carnico Grey
NEMA Negro Marquina
MARI Marianella
PTLA Port Laurent

PORT Portoro
RSDM Rosa Du Monte
CALA Calacatta
IMBR Imperador Brown

VERD Verdi Viana
THAS Ultra White Thasos
CREMA Crema Marfil

AVAILABLE ONYX

BROX Brown Onyx
PKOX Pink Onyx

CROX Cream Onyx
BKOX Black Onyx

WHOX White Onyx
GROX Green Onyx

HNOX Honey Onyx

SHERLE WAGNER INTERNATIONAL

EGG TUB 0290TUB-XXXX

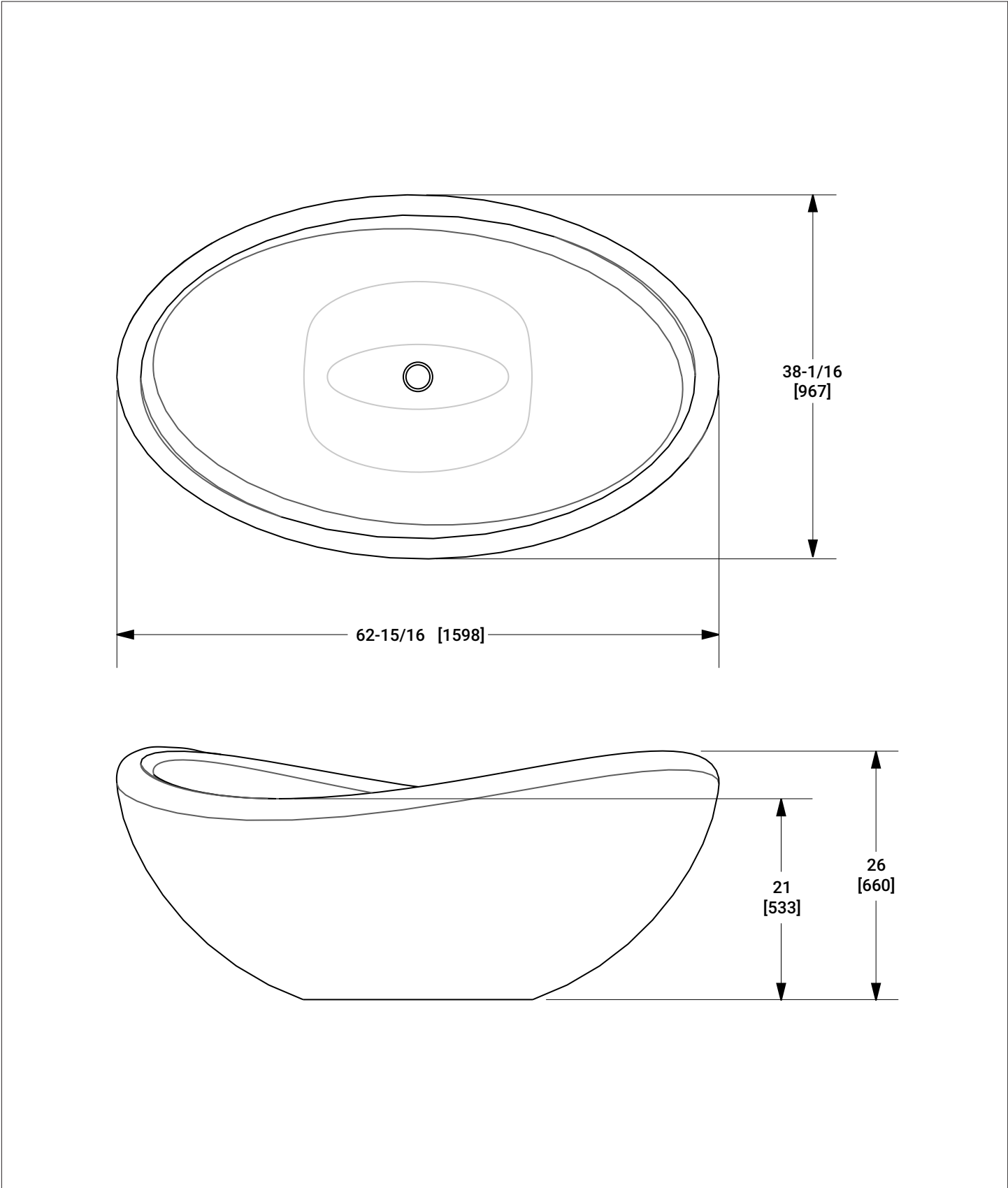

The measurements shown are for reference only. Products and specifications shown are subject to change without notice.